

Fren
Brake

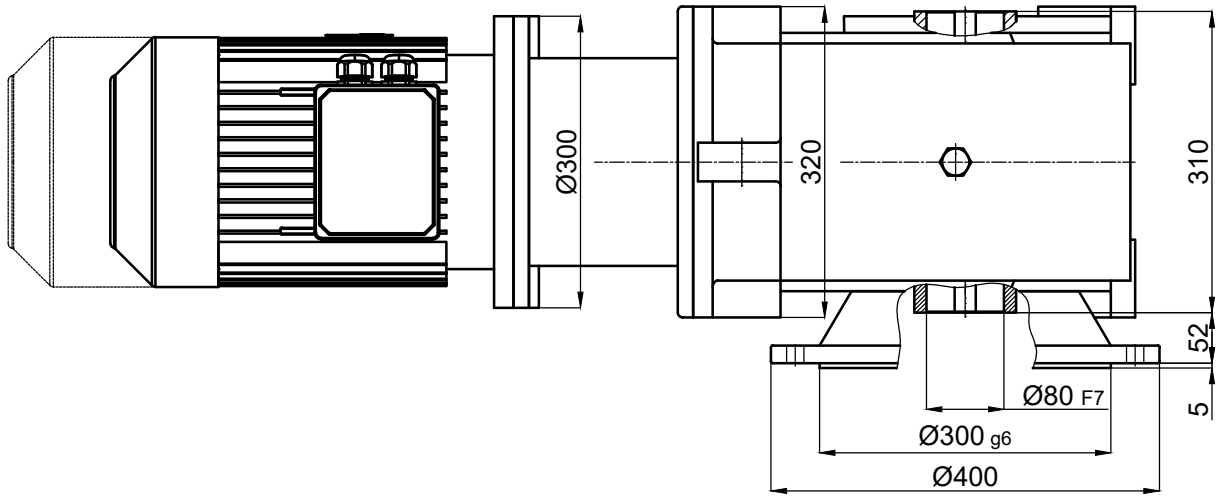

Çizen / Drawer	İsim / Name	Tarih / Date	HELİSEL VE KONİK DİŞLİLİ, MİLE GEÇME , IEC B5 FLANŞLI MOTOR ADAPTÖRLÜ, MOTORLU , FLANŞLI REDÜKTÖR HELICAL-BEVEL GEAR UNITS, SHAFT , FLANGE MOUNTED, WITH IEC B5 MOTOR ADAPTER, WITH MOTOR
Kontrol / Control			Resim No / Drawing No DZGNMF3-160/132M
Onay / Approve			Malzeme / Material - Adet / Quantity - Ölçek / Scale 1/1

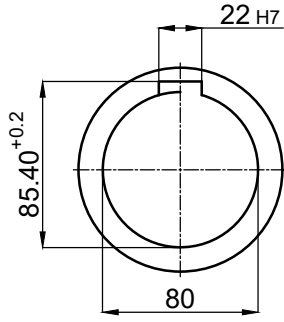