

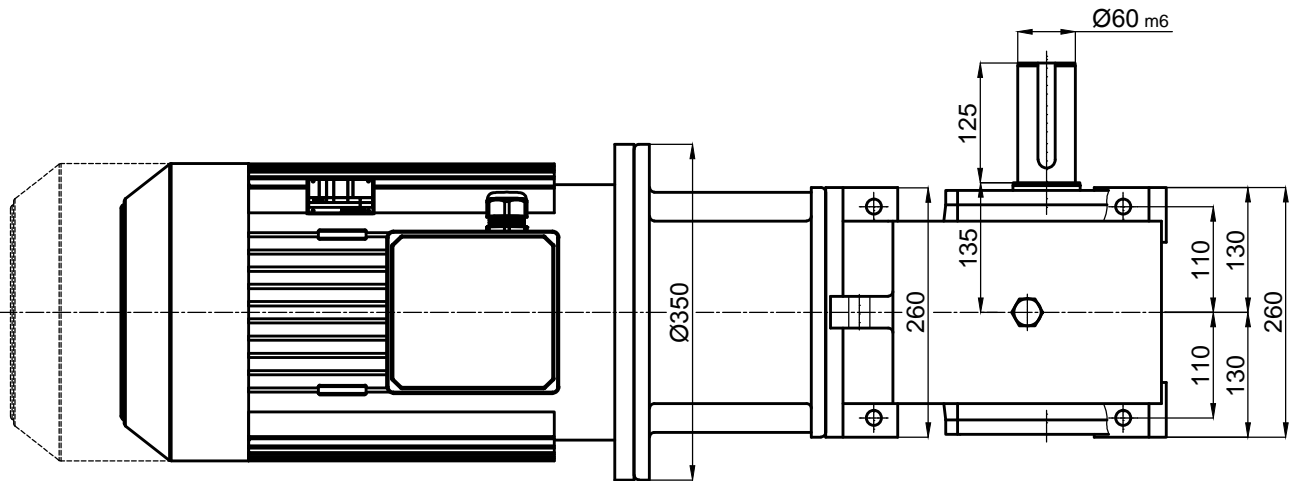

Fren  
Brake

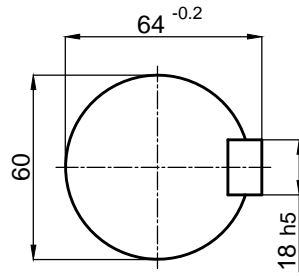

	İsim / Name	Tarih / Date	HELİSEL VE KONİK DİŞLİLİ, DOLU MİLLİ, IEC B5 FLANŞLI MOTOR ADAPTÖRLÜ, MOTORLU REDÜKTÖR HELICAL-BEVEL GEAR UNITS, SOLID OUTPUT SHAFT, WITH IEC B5 MOTOR ADAPTER, WITH MOTOR			 <b>Dişsan</b>
Çizen / Drawer	-	-	Resim No / Drawing No	<b>DZDNM3-125/160L</b>		
Kontrol / Control	-	-	Malzeme / Material	-	Adet / Quantity	-
Onay / Approve	-	-				Ölçek / Scale 1/7.5   A4